

# TM Series Couplers



## Introduction

The TM series couplers are the ideal choice where a tough, durable product of superior quality is required. They are perfectly suited to all types of industrial and transport applications.

## Construction

- ◆ Carbon steel with trivalent plating
- ◆ Standard seals are Nitrile

## Features

- ◆ Poppet valves prevent leakage when uncoupled
- ◆ Locking ball system allows for quick connect and disconnect
- ◆ Socket and plug machined from solid bar stock
- ◆ Critical parts hardened for durability
- ◆ Optimized internal flow channel provides better performance

## Specification

- ◆ Operating temperature with standard NBR seals -20°C (-20°F) to 180°C (356°F)

## Applications

- ◆ Agriculture
- ◆ Mobile equipment
- ◆ Construction equipment
- ◆ Transport Hydraulics

## Accessories

- ◆ Dust caps and plugs are available

Size	1/4	3/8	1/2	3/4	1"
MWP PSI	5800	5000	4785	4785	4785
Flow LPM	15	37.8	75.6	189	302

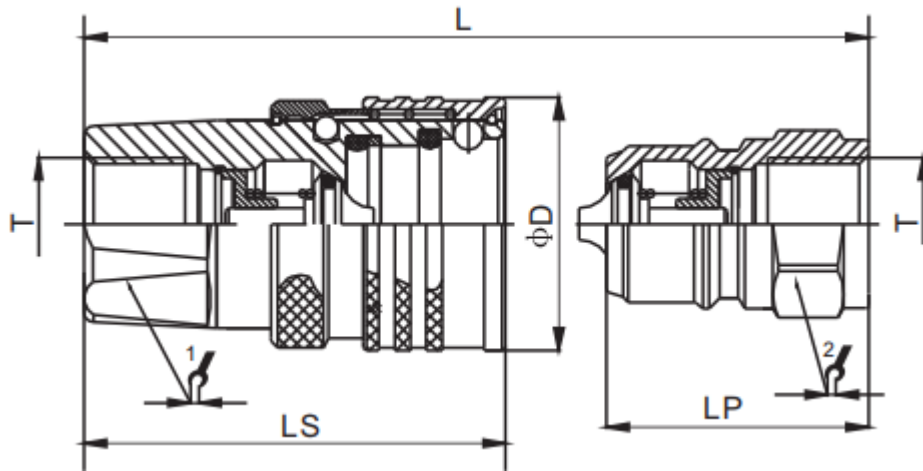

Part #		LS	LP	D	1	2	L	T
Female	Male							
TMF-04G	TMM-04G	60	48.2	26	21	18	81.8	G1/4
TMF-06G	TMM-06G	61	38	35	24	22	76.7	G3/8
TMF-08G	TMM-06G	67.5	42.5	41	30	27	85.5	G1/2
TMF-12G	TMM-12G	76.4	47	52	38	36	94.5	G3/4
TMF-16G	TMM-16G	92.4	56.5	62	45	45	113.8	G1